

Connection hoses and cables	
Water hose:	✓
Waste water hose:	✗
Electric cable:	✓ 2x

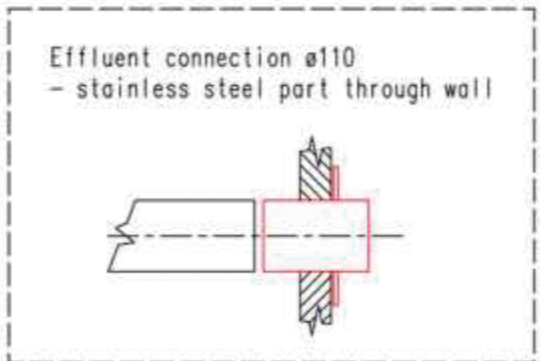
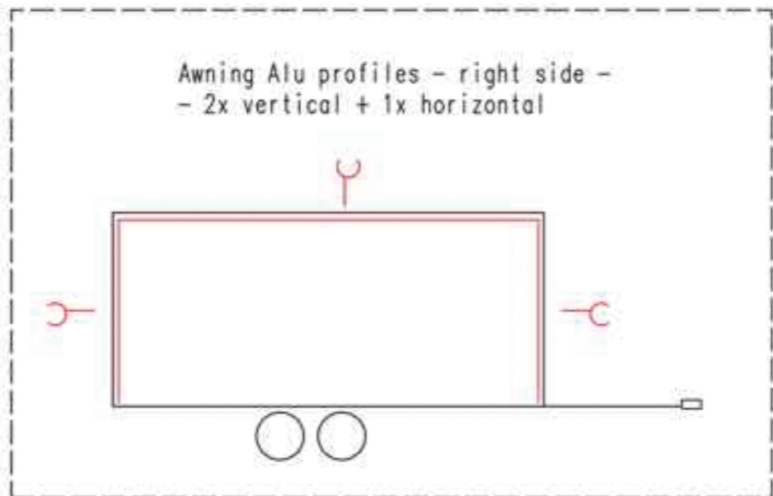
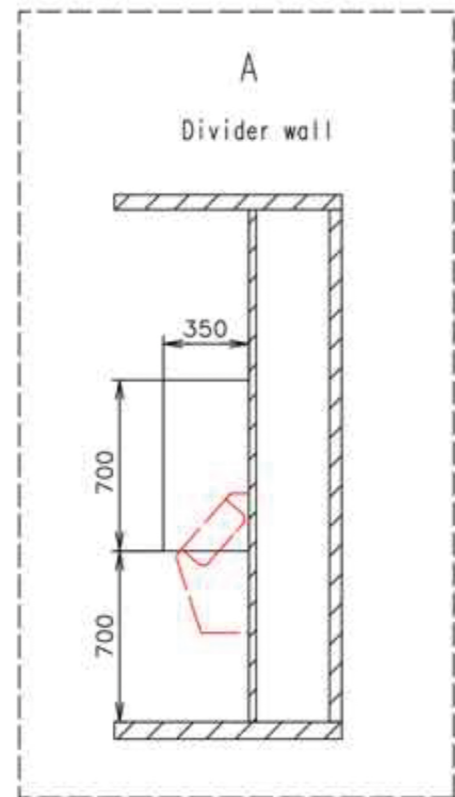
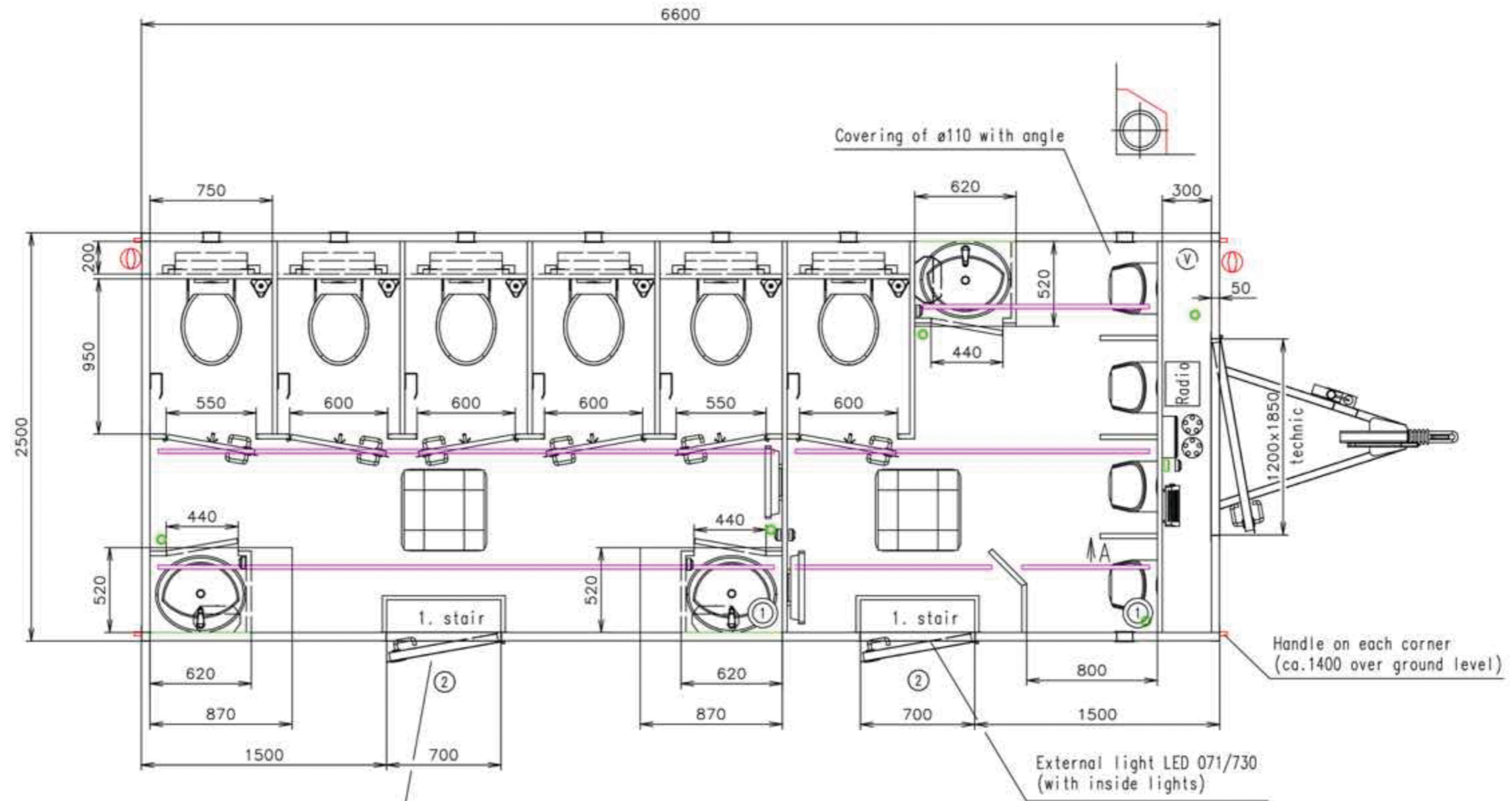

(Cabling and piping is not shown on the 3D views and drawings)

- Working desks in waterproof compact desk Egger (dark color)
- Interior doors + divider walls in black decor 6515

Notes: External doors - without cylinders Spare wheel - free loaded

Interior height:	2100 mm	Total weight:	2600 kg
Color:	RAL 7042 (gray)	Tare weight-estimate:	2200 kg
Floor:	PVC Jupiter 148708	Centre of wheels from rear side:	3400 mm
Date:	13.2.2017	Wheels:	165 R13C

Sani Mobil

Drawing number:
2556-66-1_1/2 (Sprenger)

Connection hoses and cables	
Water hose:	✓
Waste water hose:	✗
Electric cable:	✓ 2x

Ⓥ Water connection 3/4" (on the chassis)
+ filter + reduction valve

Ⓢ 2x Electric connection (through the floor) (230V-16A)
(1x heating + rear hot water boiler) (1x the rest)

Ⓣ 2x Effluent connection ø110 (through wall)
- stainless steel part

Ⓜ Power point

Ⓛ Light switch

Ⓜ Switch board (1200 over floor)

Ⓛ Light LED stripe

Ⓜ Heating (500W)

Ⓜ Heating (750W)

● Floor drain hole

Ⓜ Ventilation ø120

Ⓜ Wash-basin (built-in) Multi 1690 (550x470)
+ standard water tap

Ⓜ Hanging toilet (toilet seat - steel holders)

Ⓜ Urinal - Vitra Siko (water flush)

Ⓜ Hot water boiler Wterm FHN (5l)

Ⓜ Roof window Dometic (400x400)

Ⓜ Brush toilet

Ⓜ Toilet paper holder

Ⓜ Clothes hanger

Ⓜ Mirror (600x600) + black frame around

① Speaker

② Foldable stairs Fiona
(update on fixing of stair)
+ stainless steel handrail

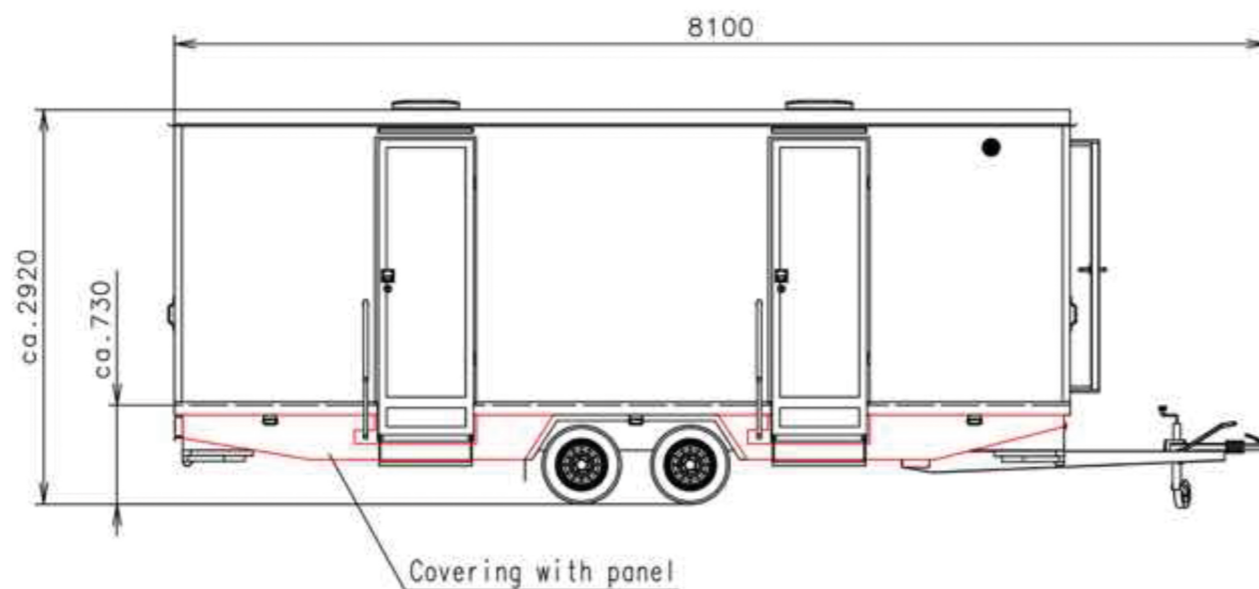

(Cabling and piping is not shown on the 3D views and drawings)

Working desks in waterproof compact desk Egger (dark color)

Interior doors + divider walls in black decor 6515

Notes: External doors - without cylinders Spare wheel - free loaded

Interior height:	2100 mm	Total weight:	2600 kg
Color:	RAL 7042 (gray)	Tare weight-estimate:	2200 kg
Floor:	PVC Jupiter 148708	Centre of wheels from rear side:	3400 mm
Date:	13.2.2017	Wheels:	165 R13C

 **Sani Mobil**

Drawing number:
2556-66-1_2/2 (Sprenger)